



FEATURES

- Lightweight – 51.8 lbs (S-shaft)
- Three-way Storage
- Easy After-Storage Start
- Highly Reliable Lubrication System
- Quiet Operation
- New Tilt System
- Offset Crankshaft
- Digital CDI
- 0.26 Gal Built-in Plastic Fuel Tank
- Over-Rev Limiter
- One-Piece Forged Crankshaft
- Shallow Water Drive (Two Position)
- Fresh Water Flush System
- Rubber-Mounted Tiller Handle
- 180° Engine Rotation (90° left, 90° right)
- Large Carrying Handle
- Steering Tension Adjuster
- Throttle Tension Adjuster

SPECIFICATIONS

	DF6A	DF4A
ENGINE TYPE	4-STROKE OHV	
FUEL DELIVERY SYSTEM	CARBURETOR	
RECOMMENDED TRANSOM HEIGHT (in.)	S: 15, L: 20	
STARTING SYSTEM	MANUAL	
FUEL TANK CAPACITY (US Gal.)	INTEGRAL 0.26 (Remote Tank Option DF6A Only)	
WEIGHT (lbs)*	S: 51.8, L: 54.0	
NO. OF CYLINDERS	1	
PISTON DISPLACEMENT (cu. in.)	8.4	
BORE X STROKE (in.)	2.38 X 1.89	
MAXIMUM OUTPUT (HP) /rpm	6.0/5250	4.0/4500
FULL THROTTLE OPERATING RANGE rpm	4750 – 5750	4000 – 5000
STEERING	TILLER	
OIL PAN CAPACITY (US Qt.)	0.74	
IGNITION SYSTEM	DIGITAL CDI	
ALTERNATOR	12V 5A (Option)	
ENGINE MOUNTING	BUSHING TYPE	
TRIM METHOD	MANUAL	
GEAR RATIO	12:23 (1.92:1)	
GEAR SHIFT	F-N-R	
EXHAUST	ABOVE PROP EXHAUST	
DRIVE PROTECTION	RUBBER HUB	
PROPELLER SIZE (in.)	○ 7-1/2 x 6 ● 7-1/2 x 6-1/2 (DF4A) ○ Optional ● Standard	
	● 7-1/2 x 7 (DF6A)	

DIMENSIONS

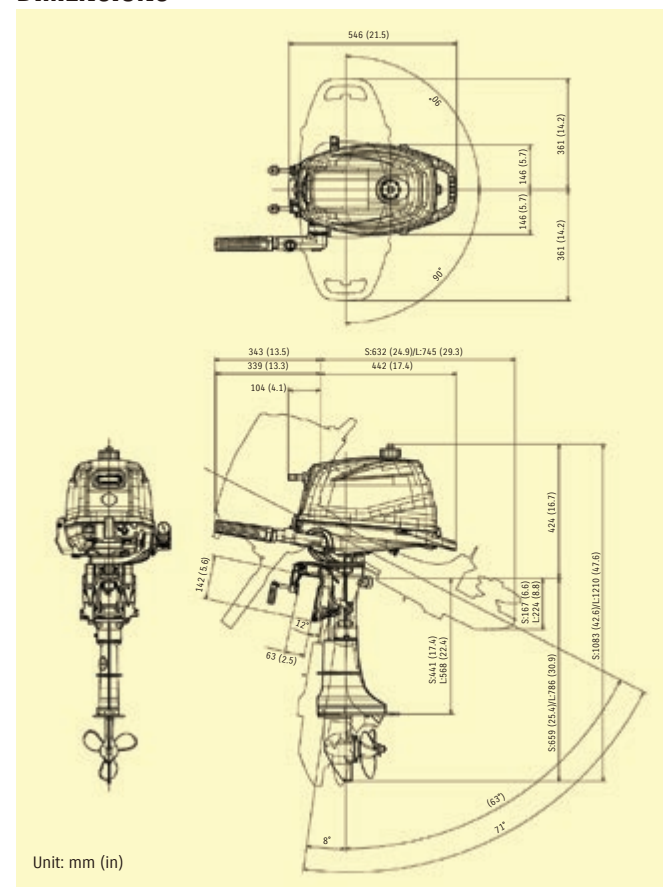

DF6A/4A

4-STROKE OUTBOARDS

PRODUCT INFORMATION

* Dry weight: including battery cable, not including propeller and engine oil.

Please read your owner's manual carefully. Remember, boating and alcohol or other drugs don't mix. Always use a personal flotation device. Please operate your outboard safely and responsibly. Suzuki encourages you to operate your boat safely and with respect for the marine environment.

Specifications, appearances, equipment, colors, materials and other items of "SUZUKI" products shown on this catalogue are subject to change by manufacturers at any time without notice and they may vary depending on local conditions or requirements. Some models are not available in some territories. Each model might be discontinued without notice. Please inquire at your local dealer for details of any such changes. Actual body color might differ from the colors in this brochure.

DF6A and DF4A – A New Generation Fully Reborn With Style Compact, Lightweight (52 lbs*) and Easy To Operate

The New DF6A and DF4A Continue The Suzuki Tradition Of Portable Performance

Bold cuts follow the popular engine cover design already featured on the DF20A/15A/9.9B and DF30A/25A. The new Nebular Black color of the body and new decals make for a stylish design. Our pursuit of progress was guided by the development concepts of “lightweight” and “easy operation.” Overhauling the existing design has achieved a comprehensive weight reduction and improved operability. We increased fuel efficiency through a bold redesign of the lubricating system, starting with a first-in-its-class** oil filter, and use of an offset crankshaft. Packed with features, such as an integral overhead fuel tank for improved maintenance, a new tilt system and an easy-to-grip carrying handle, which can prove their worth in a variety of operating conditions, the DF6A and DF4A have established themselves as the standard for portable outboards.



*S-shaft Models
**6.0 HP/4.0 HP class

Lightweight

In addition to a reinvigorated and stylish appearance, the newly designed and developed Suzuki DF6A and DF4A boast the unrivaled lightweight, 51.8 lbs (S-shaft models). Lighter weight has improved portability as well as operability.

Easy To Start After Storage

Because the integral overhead fuel tank and one-way valve allow gravity fuel supply, the engine can be started without opening the engine cover, even after long-term storage.

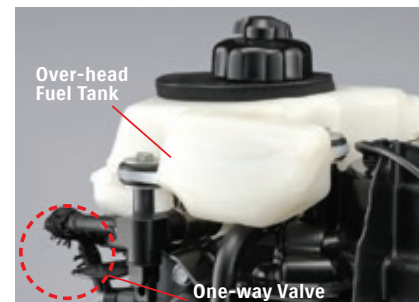

Highly Reliable Lubricating System

The forced lubrication system of the DF6A and DF4A has an additional oil passage to the upper and lower crankshaft and connecting rod big end. The addition of a first-in-its-class** oil filter greatly increases the reliability of the lubricating system. Furthermore, the new position of the oil window allows for visual confirmation of the actual lubricating condition.



Oil filter

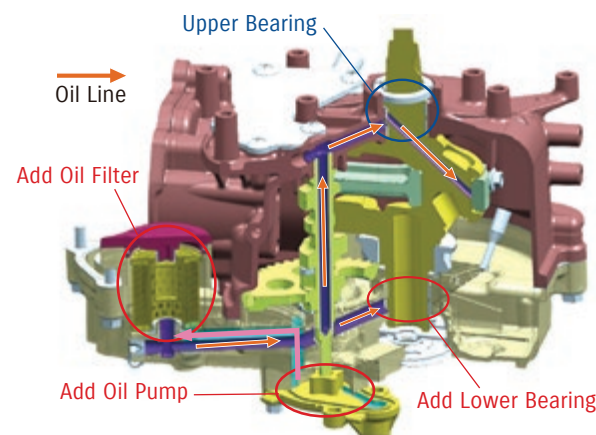

Offset Crankshaft

Positioning the crankshaft slightly off center of the cylinder reduces lateral pressure against the cylinder wall as the piston moves up and down in the cylinder. The result is smoother piston movement, which improves operating efficiency.

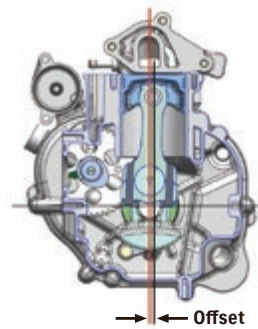

Quiet Operation

The low noise level is the result of a silencer, designed to optimize the capacity and shape of the air intake. The new design of the rocker arm and the plane bearing of the crankshaft also help reduce the noise level. We also changed the structure of the parts related to the rocker arm and eliminated its excessive play. In addition, we changed the crankshaft bearing from a common ball type to a plane type.

Comparison (New DF6A vs. DF6)

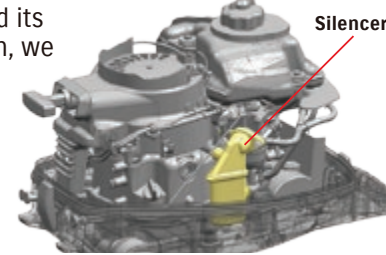
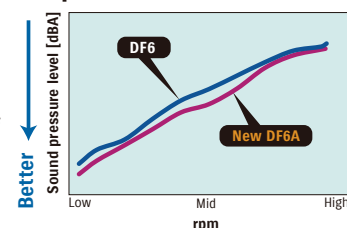

Three-Way Storage

The new fuel and lubricating systems allow more convenient storage of the outboard on any of three sides (port, starboard or front) without worrying about the storage orientation.

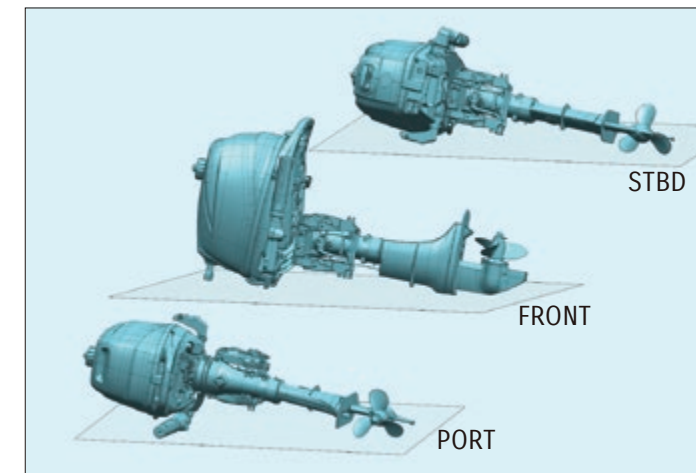

Improved Portability

The carrying handle integrated into the lower cover has been rounded and made easier to hold. An additional grip at the front of the lower engine cover provides the convenience of carrying the outboard with both hands.



New Tilt System

The tilt system of the DF6A and DF4A offers different up-and-down paths of the shallow drive arm compared with the previous models. When raised, it can be locked at three positions.



When lowered, it can just be smoothly moved to its lowest position without locking.

Suzuki's Anti Corrosion System

Suzuki protects its outboards with an anti-corrosion finish specially developed by Suzuki. Applied directly to the aluminum surface it maximizes the bond between the finish and the surface, increasing the protection and durability of parts that are constantly exposed to saltwater.

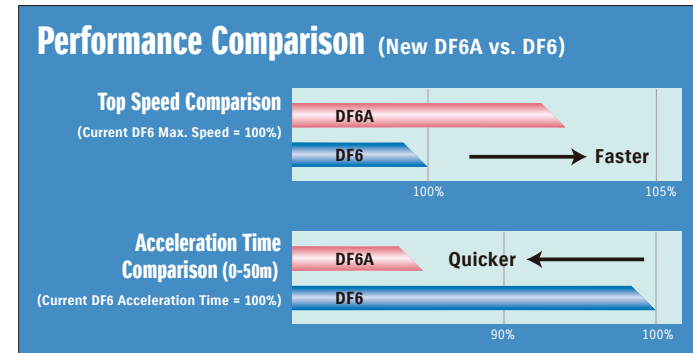
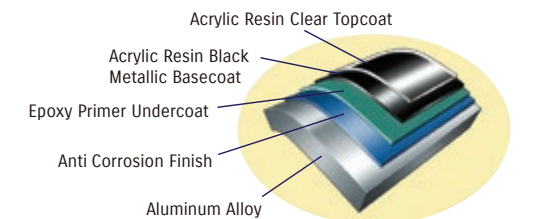

Data used in the graphs were obtained through "In-House Suzuki Testing" under uniformed conditions. Results will vary depending upon operating conditions (boat design, size, weight, weather, etc.)

Outstanding Handle Operation

An ease of handling that has enjoyed great popularity. Further improvements to the tiller handle have successfully mitigated vibrations contributing to fatigue and stress when transmitted to the hand during operation. The DF6A and DF4A excel at vibration mitigation, particularly in the mid-range.

Lower Emissions, Efficient Operation

Suzuki's advanced four-stroke technologies deliver highly efficient operation and lower emissions. This allows Suzuki outboards to conform to some of the world's strictest standards*1 and receive a three-star rating from the California Air Resources Board (CARB).

*1 Emission standards compliance is region specific.

